

3M™ Impact Protection Adhesive Attachment System Installation Instructions



3M™ Impact Protection Adhesive improves the overall performance of 3M™ Safety and Security Window Films. This unique window protection system combines the toughness of 3M's patented micro-layer safety film with 3M's world-class expertise in adhesives to help shield against impact energy from severe weather, earthquakes, bomb blasts or forced entry events. The 3M Impact Protection System also helps protect against personal injury from flying glass.

3M Impact Protection Adhesive:

- Commercial and Residential Applications
- Bomb Blast and Windstorm Testing results available upon request.



The following procedure describes the materials and steps that are necessary to install the 3M™ Impact Protection Adhesive attachment system.

Recommended Products:

- 3M™ Citrus Base Cleaner
- 3M™ Adhesive Remover, Citrus Base
- 3M™ Foaming Glass Cleaner
- 3M™ Super Fine Synthetic Steel Wool Pad
- 3M™ Scotch™ Safe Release™ Masking Tape
- 3M™ Scotch™ Long Mask™ Masking Tape
- 3M™ Impact Protection Adhesive

Window Preparation

Glass panel shall be uniform in appearance. No fractures, holes or what is considered contaminated glass, or damaged glass, to be present.

Window frame to be uniform in appearance and free from dents, holes and cracks within two inches of the glass.

A thorough cleaning of the glazing and frame systems before applying film and attachment is required to remove all foreign matter and contaminants such as adhesives, grease, oil, dust, water, surface dirt, old sealant or glazing compounds by using 3M Citrus Base Cleaner, alcohol or commercial cleaning solution.

Detergent or soap and water treatments are not recommended for this step.

- 1. IPA does not require the glazing stop to be trimmed. Note: If the glazing stop overlaps frame, trimming the glazing stop is optional. (Reference Detail 1 on back.)**
2. Spray the glazing bead, glass and frame surface with an appropriate cleaning product and remove with a lint free cloth. Repeat if necessary to remove all foreign materials from the glass and inside window frame surfaces. If the area is particularly dirty, a light scrub with a 3M 0000 Super Fine Synthetic Steel Wool Pad is recommended to loosen contaminates. Finish with a final cleaning if needed.
3. Spray the glass with 3M Foaming Glass Cleaner or a soap and water solution. Flush the glazing bead to glass area starting at the top and working down to drain or remove any remaining contaminant from the area. Scrape the glass with a razor to remove all foreign matter. Thoroughly clean the glass a final time with soapy water and a window cleaning squeegee. Wipe around the glazing bead and frame area one final time to remove all of the soap and water solution.

Film Installation

1. Apply the 3M™ Ultra Safety & Security Window Film to the glass, making sure that the film is installed as far into the glazing channel as possible. Cut film as you normally would around the remaining glazing bead. **Remember to leave enough spacing between film and glazing bead to facilitate the removal of the slip solution.**
2. Squeegee the film to the glass by pressing firmly to remove as much of the slip solution as possible, especially at the edges of the film. **Two “edge-drying” methods can be used before applying the Impact Protection attachment system.**
 - A. The panels can be left for a few weeks to ensure proper drying of the film before the IPA system is applied.
 - OR –
 - B. Using a hair dryer, gently heat and bump the edges of the film to hasten the removal and drying of the water from the edges. **Make sure that all of the soap and water solution has been removed from the film/glass/glazing channel before applying the IPA attachment system.**



Impact Protection Adhesive Installation

1. Apply a 1" (25mm) strip of 3M™ Scotch™ Safe Release™ White Masking Tape to the ultra film surface 3/8" (9mm) in from the edge of the film to all four sides. **Note:** This dimension will depend on application— 1/2" or 3/8".
2. Apply a 1" (25mm) strip of 3M Safe Release Blue Masking Tape to the window frame 3/8" (9mm) from the edge of the trimmed gasket. This will form a parallel sealant channel that will allow a uniform sealant bead to be applied to the glass/frame interface. **Note:** Use a clean drop cloth before proceeding to Step 3.
3. Apply a triangular bead of IPA Impact Protection Adhesive, and tool as needed to form an acceptable finish. Refer to Figure 1. **Read and follow all product information and installation instructions provided by 3M Company.** We recommend you start in a corner and apply the sealant bead out approximately 6". Then turn the gun and push the sealant bead to the next corner where the same method is repeated. **Pushing the sealant bead will insure proper penetration and minimize the chances of air gaps in the bead.** Pulling the gun can also be done if confident no air gaps are formed.
4. Smooth the sealant bead with an appropriate tool, if necessary, to give a finished look.

Detail 1. 3M™ IPA System Typical Configuration

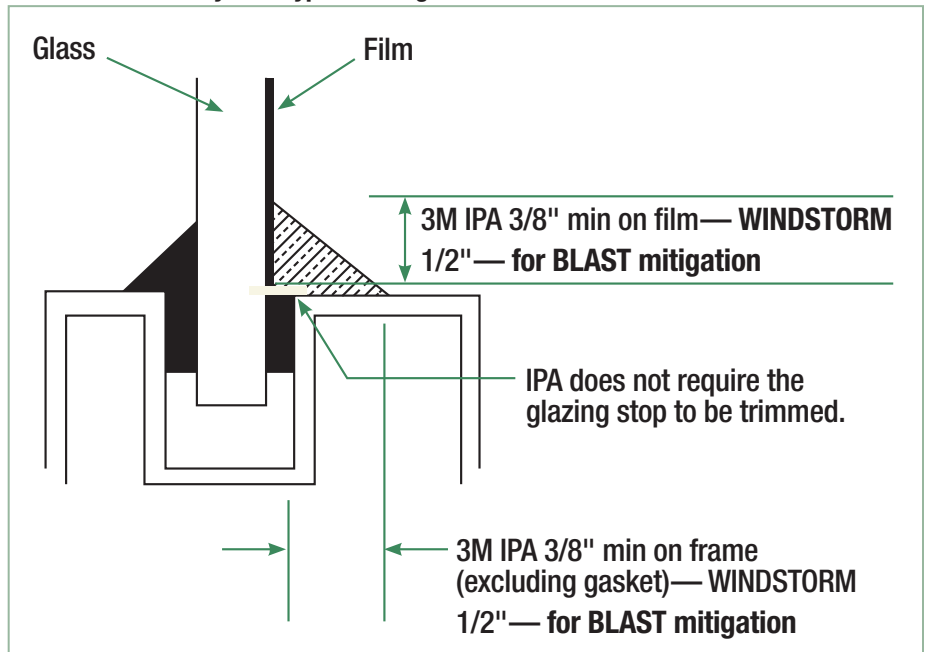

Tooling should be completed in one continuous stroke immediately after adhesive application and before a skin forms.

5. Carefully remove the two masking strips from the glass/frame immediately after tooling. Do not allow the excess adhesive to contact the film, frame or flooring surfaces. A light colored drop cloth is needed to protect the work area. **Be careful not to step on adhesive and transfer it to surrounding surfaces.**

Note: Should you get some of the adhesive on the surrounding surfaces, an application and gentle wipe with a 3M Citrus Based Cleaner is recommended.

Curing time for the IPA will vary depending on temperature and relative humidity. It is not recommended to clean the film/IPA system for at least 36 hours following the installation. Full curing/adhesion can take up to 7 days, depending on conditions.

Table 1

Property	Test Method Used	Units	3M IPA
Curing Time (25°C (77°F), 50% RH)		days	3-7
Full Adhesion		days	7-14
Tack-Free Time (25°C (77°F), 50% RH)	ASTM D5895	minutes	21
Flow, Sag or Slump		inches	0
Working Time (25°C (77°F), 50% RH)		minutes	10-20
Specific Gravity		n/a	1.403
VOC content		g/L	16
As Cured — After 21 Days at 25°C (77°F), 50% RH			
Ultimate Tensile Strength	ASTM D0412	psi (Mpa)	380 (2.62)
Ultimate Elongation	ASTM D0412	%	640
Durometer Hardness, Shore A	ASTM D2240	points	38-39
Tear Strength, Die B	ASTM D0624	ppi	72

Bomb Blast and Windstorm Testing results available upon request.

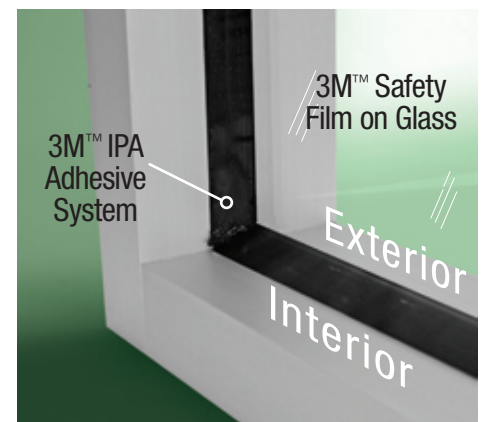

IMPORTANT NOTICE: 3M MAKES NO PERFORMANCE PROMISES OR OTHER REPRESENTATIONS ABOUT THE EFFECTIVENESS OF THE IPA ATTACHMENT SYSTEM FOR USE WITH 3M WINDOW FILM IN A PARTICULAR APPLICATION. All statements, technical information and recommendations contained in these IPA Attachment System installation instructions are based on tests believed to be reliable. However, many factors beyond the control of 3M can affect the use and performance of the 3M products in particular applications. Because these factors are uniquely within the user's knowledge and control, it is essential that the user evaluates and determines whether the 3M Ultra Safety & Security Window Film and/or 3M Impact Protection Adhesive Attachment System are appropriate for the particular application.



Building and Commercial Services Division

3M Center, Building 223-2N-21
St. Paul, MN 55144-1000
www.3M.com/windowfilm

3M, Long Mask, Safe Release and Scotch are trademarks of 3M Company.
Please recycle. Printed in U.S.A.
© 3M 2008. All rights reserved.
70-0709-0322-7

For more information,
please call **1-800-480-1704**
or visit us at www.3M.com/windowfilm